

Table of Contents for Light Duty plow blade:

Arctic Light Duty Poly Blade 2019 & Newer 84" & 90" .....2

Shoe kit for 2019 & Newer Light Duty Poly Blade .....8

Arctic Light Duty Poly Blade 2018 & Older 78" & 84" .....9

Important note:

Lift frame for this blade is QLII- MKBX-M3493

For more information about lift frame, check under Lift frame section.

# ARCTIC LD-P BLADE

Arctic Light Duty Plow Blade 84" & 90"

2019 & newer

 **Warning**

Do not exceed GVWR or GAWR, including blade and ballast. The rating label is found on the driver side vehicle door corners.

Lower the blade when the vehicle is parked. Temperature changes could change hydraulic pressure, causing the blade to drop unexpectedly or damaging hydraulic components. Failure to do this can result in serious personal injury.

Servicing the trip springs without special tools and knowledge could result in personal injury. See Arctic authorized dealer for service.

Inspect snowplow components and bolts for wear and damage when mounting or removing snowplow and before traveling.

Keep hands and feet clear of the blade, A-frame and cylinders when mounting or removing the snowplow. Moving or falling assemblies could cause personal injury. Never use a finger to check an alignment. Moving or falling assemblies could crush your finger.

Do not stand between the vehicle and the blade or within 10' of a moving blade. A moving or falling blade could cause personal injury.

To prevent accidental movement of the blade, always turn the control OFF whenever the snowplow is not in use.

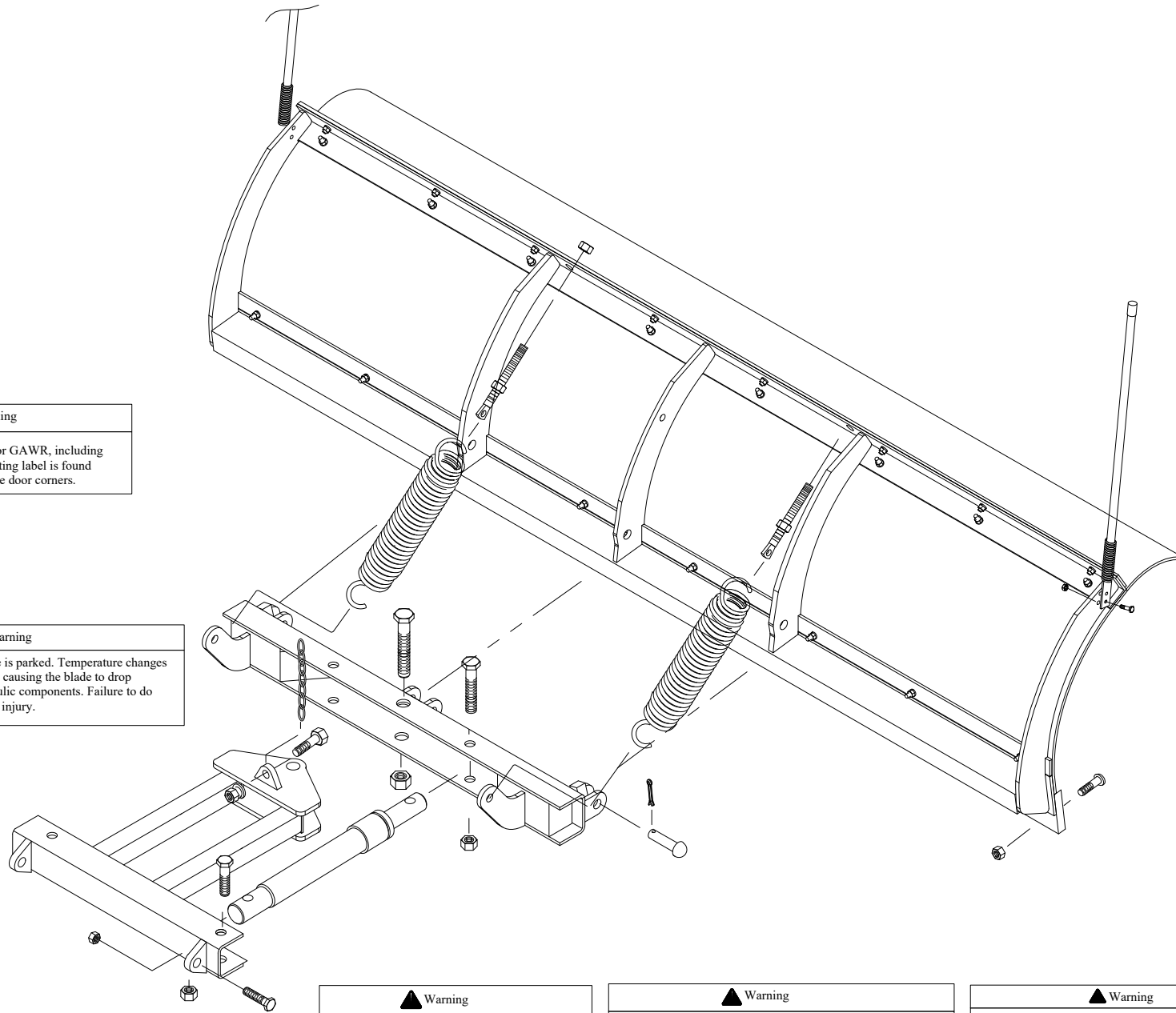

**Warning**

Do not exceed GVWR or GAWR, including blade and ballast. The rating label is found on the driver side vehicle door corners.

**Warning**

Lower the blade when the vehicle is parked. Temperature changes could change hydraulic pressure, causing the blade to drop unexpectedly or damaging hydraulic components. Failure to do this can result in serious personal injury.

**Warning**

Inspect snowplow components and bolts for wear and damage when mounting or removing snowplow and before traveling.

**Warning**

Keep hands and feet clear of the blade, A-frame and cylinders when mounting or removing the snowplow. Moving or falling assemblies could cause personal injury. Never use a finger to check an alignment. Moving or falling assemblies could crush your finger.

**Warning**

Do not stand between the vehicle and the blade or within 10' of a moving blade. A moving or falling blade could cause personal injury.

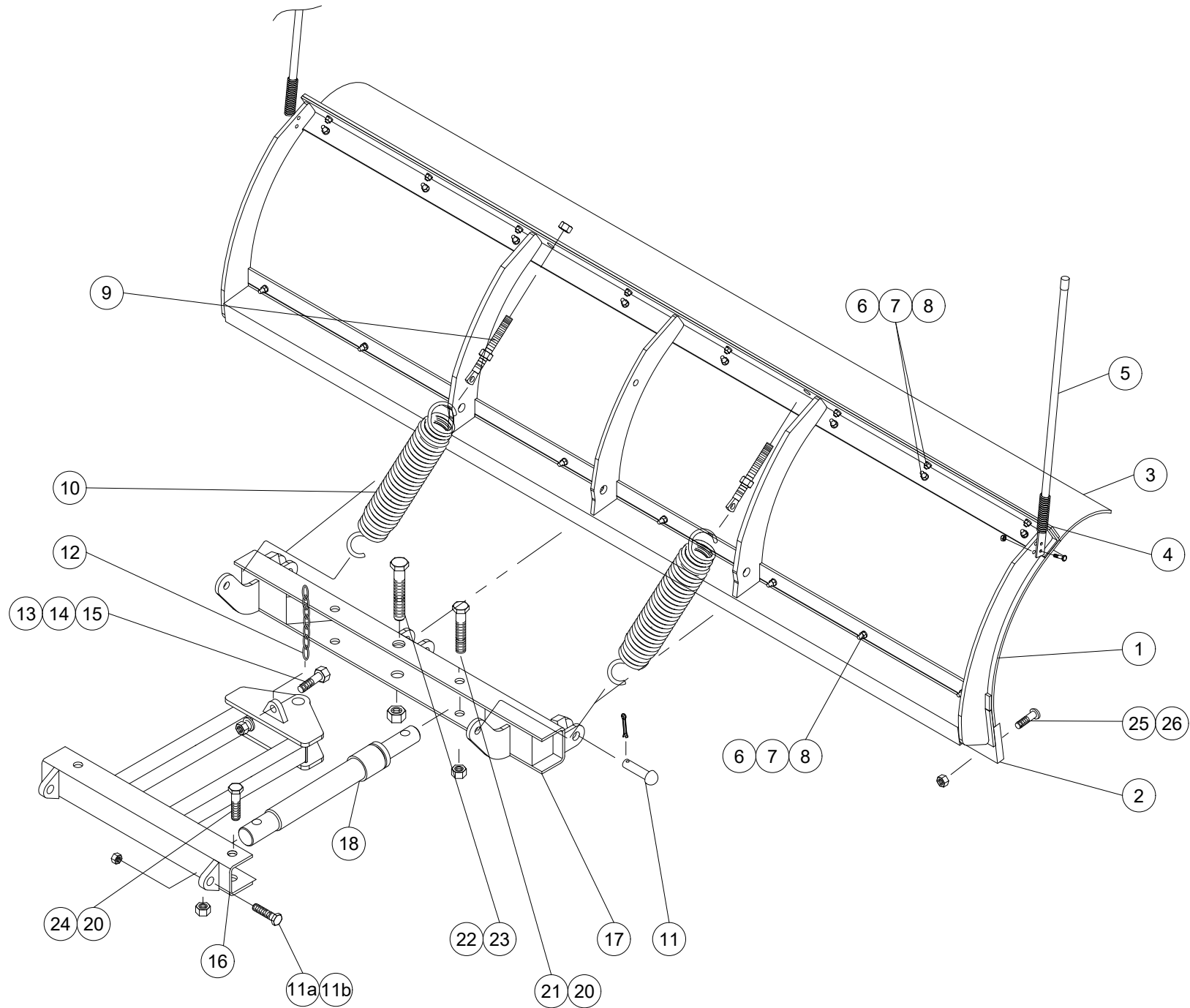

Light Duty Plow Blade Assembly, Hardware kit, Power Angling Assembly					
Item	Part #	Description	Quantity		
			90" Blade- 53667-LD 84" Blade- 53667-84-LD	Hardware Kit 53244-M	Power angling 53243-M-GA
1	52994-D	Poly skin (1/4"x18 1/2") – 90"	1		
1a*	53143-B	Poly skin (1/4"x18 1/2") – 84"	1		
2	53688-B	Poly Cutting Edge – 1" x 4" x 90"	1		
2a*	53688-84-B	Poly Cutting Edge – 1" x 4" x 84"	1		
3**	52995-CR	Curved Deflector – 90" Optional	1		
3a**	53144-CR	Curved Deflector – 84" Optional	1		
4**	52996-M-GA	Strap – 90" Optional	1		
4a**	53145-B	Strap – 84" Optional	1		
5	50999-2	Blade guides	2		
6	HH-00971-044	5/16"-18x1.1/4 Carriage bolt	16		
7	HH-00294-002	5/16"-18 Hex Nut	16		
8	HH-00457-007	5/16" lock washer	16		
9	50191-M	Eye bolt Ass'y		2	
10	50180-C	Trip Spring		2	

Light Duty Plow Blade Assembly, Hardware kit, Power Angling Assembly					
Item	Part #	Description	Quantity		
			90" Blade- 53667-LD 84" Blade- 53667-84-LD	Hardware Kit 53244-M	Power angling 53243-M-GA
11	50232-M	¾" x 3" Rivet Assy		3	
11a	HH-00972-134	5/8" x 3" HHCS		2	
11b	HH-00540-002	5/8" Nylon Insert		2	
12	55018-02-M	Chain		1	
13	HH-00972-090	½"-20x1.1/2 Cap Screw		1	
14	HH-00460-002	½"-20 Hex Nut		1	
15	HH-00457-001	½" lock washer		1	
16	52647-D-GA	T-frame			1
17	53003-B-GA	Quadrant			1
18	CS-150-10.00 NRS	1.1/2"x10" Angling Cylinder			2
19*	HH-00233-001	1/4-28 Grease Fitting			1
20	HH-00973-007	3/4" Hex Nut Nylon Insert			4
21	HH-00972-156	3/4"-16x4 1/2 Cap Screw			2
22	HH-00972-192	1"-14 x 5.1/2" Cap screw			1
23	HH-00540-009	1" Nylon Insert Locknut			1

Light Duty Plow Blade Assembly, Hardware kit, Power Angling Assembly					
Item	Part #	Description	Quantity		
			90" Blade- 53667-LD 84" Blade- 53667-84-LD	Hardware Kit 53244-M	Power angling 53243-M-GA
24	HH-00972-153	¾"-16x3.1/2 Cap screw			2
25	HH-00971-138	½"x2" Carriage bolt	8		
26	HH-00340-003	½" Nylon Insert Locknut	8		

**Note:** \* These items are not shown on the drawing.

\*\* Optional, not available in Blade Assembly.

### Installation Instructions

1. Lay blade face down on the floor. Attach quadrant (17) to blade by inserting rivets (11) through the holes in the quadrant lugs and blade ribs. Install the center one first. Secure the rivets with the cotter pins.
2. Take an eye bolt (9) and screw one 5/8" nut all the way down the thread. Attach spring (10) to the quadrant and the eye bolt, making sure the open end of the spring faces up on the quadrant. Lift the quadrant and insert the eye bolt through the corresponding hole in the spring plate. Secure the eye bolt with another 5/8" nut. This will hold the quadrant in an upward position, and ease installation of the remaining spring and eye bolt.
3. Tighten the eye bolt upper nut until the spring coils just break loose from each other. Secure eye bolts in position by tightening the lower nut against the blade spring plate.
4. Lift chain (12) is attached by inserting a ½" bolt (13) through the last link and in the hole in the T-frame lifting bar. Tighten a ½" nut (14) and lock washer (15) firmly from the face side of the lifting bar.

To attach snowplow to vehicle mount, proceed as follows:

1. Position the vehicle such that the T-frame lugs and vehicle mount are in vertical alignment.



2. Hook the chain into the lift channel slot.
3. Actuate lift cylinder slowly. Blade will remain on the ground, but the T-frame will begin to rise. Continue until the T-frame lug holes align with the holes on the vehicle mount.
4. Insert the spreader pins (11) through the holes to attach the T-frame to the vehicle mount. Secure attachment by inserting cotter pins into the spreader pins.
5. With the control switch in the DOWN position, push the lift channel downward as far as possible and adjust the chain so there are two links of slack.

Arctic Equipment Manufacturing Corporation reserves the right under its product improvement policy to change construction or design details and furnish equipment when so altered without reference to illustrations or specifications used.

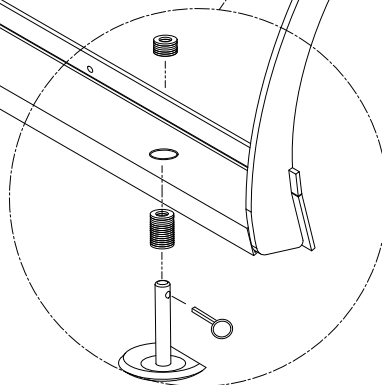
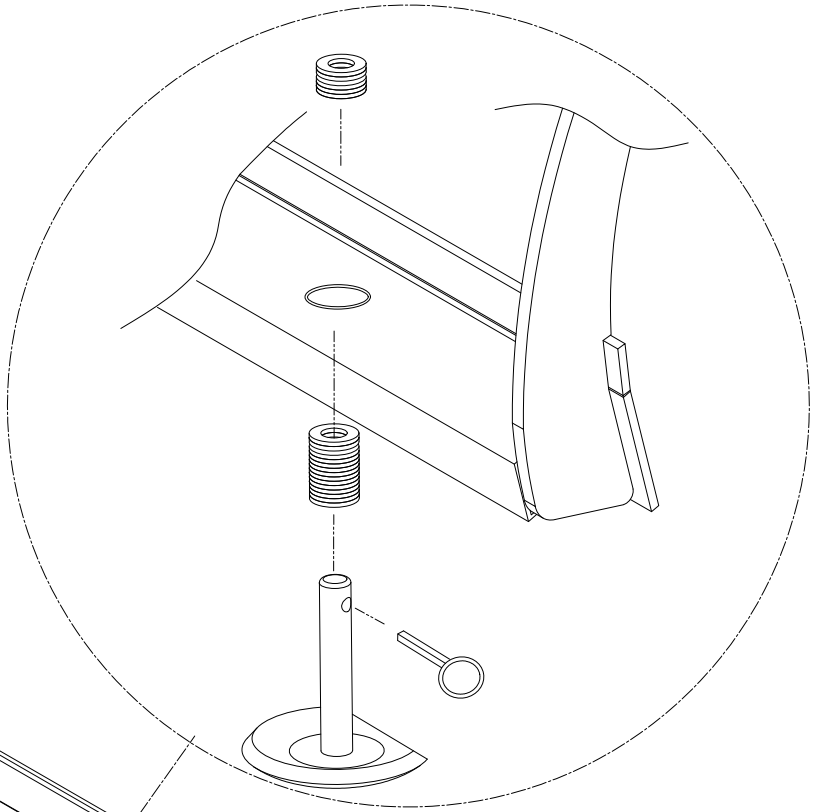
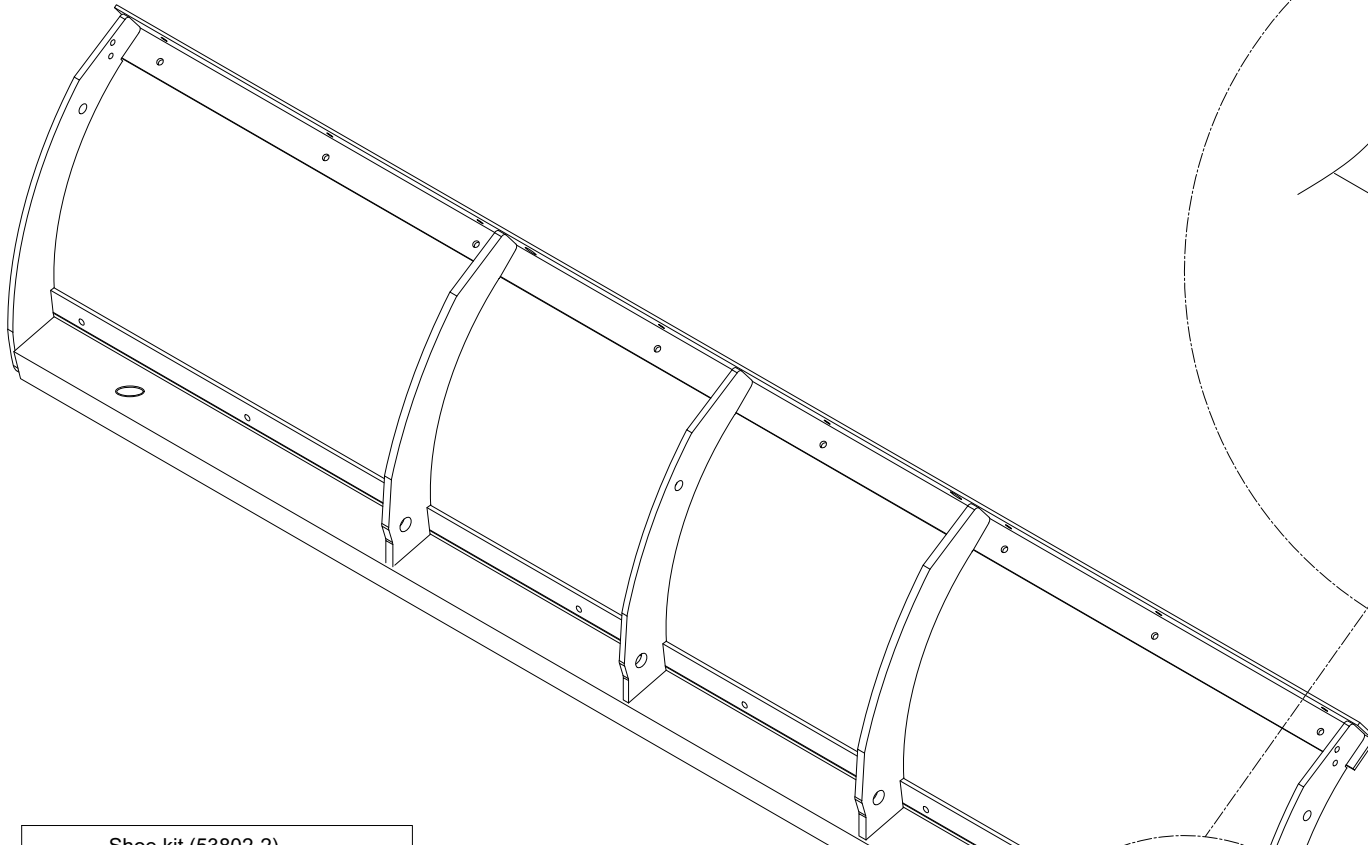

Shoe kit (53802-2)			
Sr#	Part #	Description	Qty
1	53803-B	Shoe	2
2	55017-N	1" Flat Washer	80
3	50040-A	Quick Release Pin	2

**Instructions:**

1. Insert the long shaft in pipe sleeve on the blade. Secure other side of shaft with flat washers
2. Adjust these flat washers accordingly to level the blade on right spot

# ARCTIC LD-P

Arctic Light Duty Poly Blade 78" & 84"

2018 & older

**▲ Warning**

Lower the blade when the vehicle is parked. Temperature changes could change hydraulic pressure, causing the blade to drop unexpectedly or damaging hydraulic components. Failure to do this can result in serious personal injury.

**▲ Warning**

Do not exceed GVWR or GAWR, including blade and ballast. The rating label is found on the driver side vehicle door corners.

**▲ Warning**

Inspect snowplow components for wear and damage when mounting or removing snowplow and before traveling.

**▲ Warning**

Keep hands and feet clear of the blade, A-frame and cylinders when mounting or removing the snowplow. Moving or falling assemblies could cause personal injury. Never use a finger to check an alignment. Moving or falling assemblies could crush your finger.

## Arctic Light Duty Poly Blade, Quadrant & T-frame

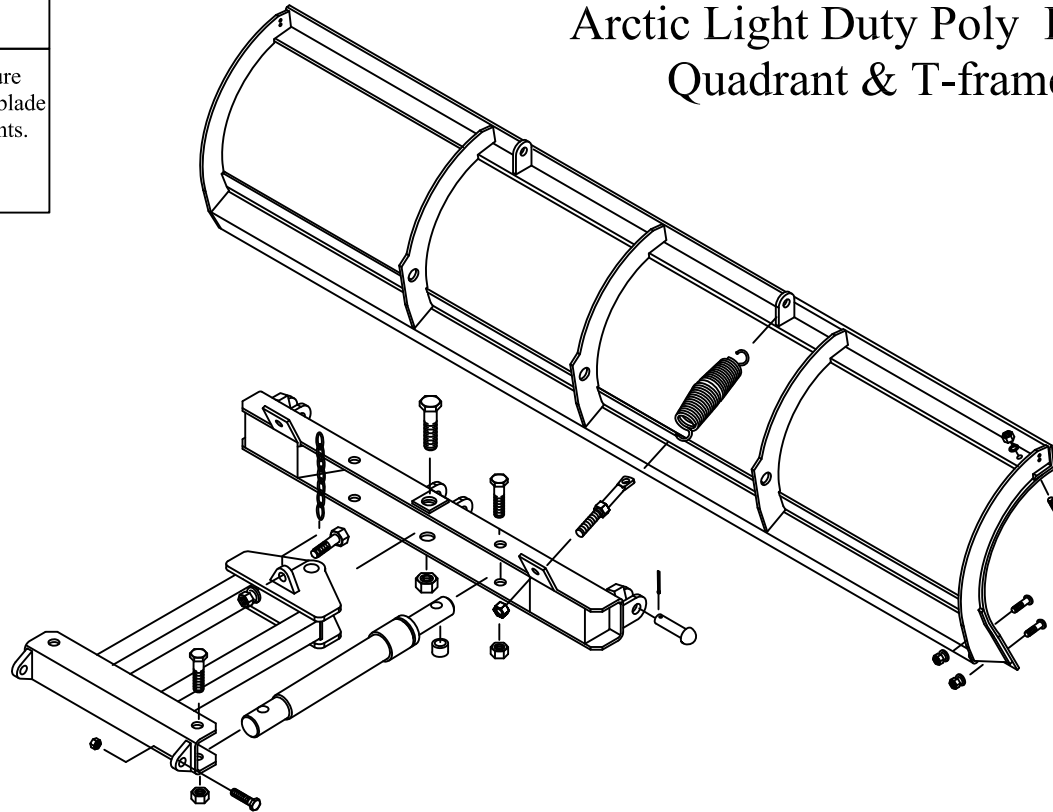

**▲ Warning**

Do not stand between the vehicle and the blade or within 10' of a moving blade. A moving or falling blade could cause personal injury.

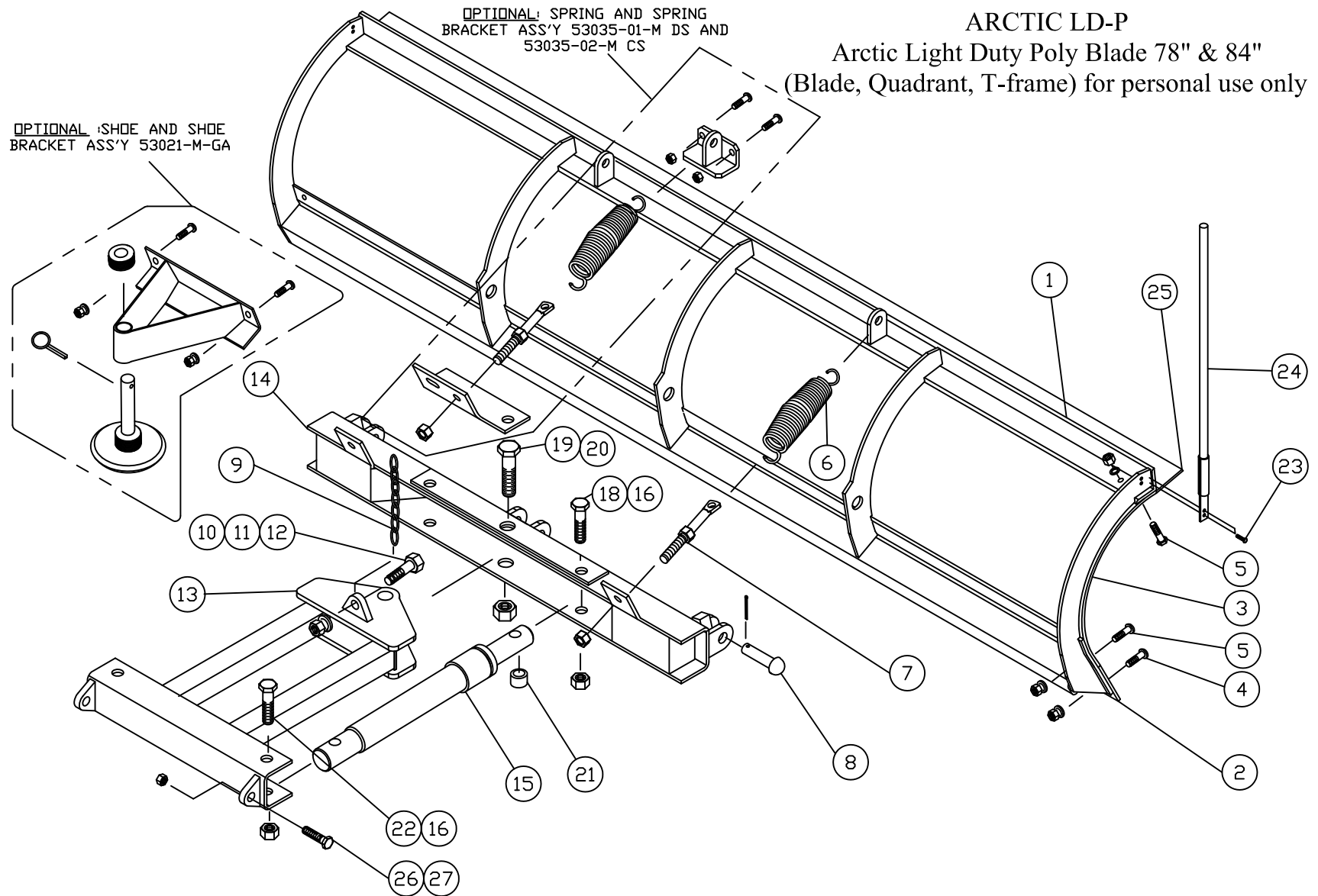

 Warning

Do not exceed GVWR or GAWR, including blade and ballast. The rating label is found on the driver side vehicle door corners.

Lower the blade when the vehicle is parked. Temperature changes could change hydraulic pressure, causing the blade to drop unexpectedly or damaging hydraulic components. Failure to do this can result in serious personal injury.

Servicing the trip springs without special tools and knowledge could result in personal injury. See Arctic authorized dealer for service.

Inspect snowplow components and bolts for wear and damage when mounting or removing snowplow and before traveling.

Keep hands and feet clear of the blade, A-frame and cylinders when mounting or removing the snowplow. Moving or falling assemblies could cause personal injury. Never use a finger to check an alignment. Moving or falling assemblies could crush your finger.

Do not stand between the vehicle and the blade or within 10' of a moving blade. A moving or falling blade could cause personal injury.

To prevent accidental movement of the blade, always turn the control OFF whenever the snowplow is not in use.

Plow Blade Assembly, Power Angling Kit & Hardware Kit			
Item	Part Number	Description	Quantity
1	52626-78-M-GA	Blade Assembly 78" (includes poly skin, cutting edge & bolts)	1
	52626-84-M-GA	Blade Assembly 84" (includes poly skin, cutting edge & bolts)	1
2	52634-B	Cutting Edge 78"	1
	52635-B	Cutting Edge 84"	1
3	52637-78-B	Poly Skin 78"	1
	52637-84-B	Poly Skin 84"	1
4	52593-M	Carriage Bolt Assembly (1/2" x 1 3/4" & nut)	8
5	52288-01-M	Carriage Bolt Assembly (5/16" x 1 1/4" & nut)	16
6**	52663-N	Spring	2
7**	50191-M	Eye bolt Assembly (eye bolt 5/8" & 2 nuts)	2
8**	50232-M	Rivet Assembly (rivet 3/4" x 3" & cotter pin)	3
9**	55018-02-M	Chain	1
10**	HH-00972-090	Bolt, 1/2" x 1 1/2 Hex Head Cap Screw	1
11**	HH-00457-001	Lock washer, 1/2"	1
12**	HH-00460-002	Hex Nut, 1/2"	1
13*	52647-D-GA	T-frame	1
14*	52654-B-GA	Quadrant	1
15*	CS150-10.00-NRS	1 1/2" X 10" angling cylinder	2
16*	HH-00973-007	3/4" Hex Nut Nylon Insert	4
18*	HH-00972-156	3/4" x 4 1/2 UNF Hex Head Cap Screw	2
19*	HH-00972-192	1" x 5 1/2" UNF Hex Head Cap Screw	1
20*	HH-00540-009	1" Nut with Nylon Insert	1
21*	52712-N-GA	Spacer for L/D cylinder	2
22	HH-00972-153	3/4" x 3 1/2 UNF Hex Head Cap Screw	2
23	GB001	Guide Bolt Ass'y	4
24	50999-B	Blade Guide	2
25	52797-D	78" Light Duty Poly Deflector	1
	52798-D	84" Light Duty Poly Deflector	1
26**	HH-00972-134	5/8" x 18 - 3" Hex head Cap Screw	2
27**	HH-00540-002	5/8" Hex Nut Nylon Insert	2

\* Part of power Angling Kit 52696-M-GA

\*Part of Hardware Kit 52695-M

---

### Installation Instructions

1. Lay blade face down on the floor. Attach quadrant (14) to blade by inserting rivets (8) through the holes in the quadrant lugs and blade ribs. Secure the rivets with the cotter pins.
2. Take an eye bolt (7) and screw one nut all the way down the thread. Attach spring (6) to the blade and the eye bolt. Lift the quadrant and T-frame (power angling assembly) assembly and insert the eye bolt through the hole on the corresponding hole in the quadrant. Secure the eye bolt with another nut. This will hold the quadrant in an upward position, and ease installation of the remaining spring.
3. Tighten the eye bolt lower nut until the spring coils just break loose from each other. Secure eye bolts in position by tightening the upper nut against the quadrant plate.
4. Grease needs to be applied in the bushing through the grease fitting.
5. Lift chain (9) is attached by inserting a ½" bolt (10) through the last link and in the lug on the T-frame. Tighten a ½" nut (12) and lock washer (11) firmly from the face side of the lifting bar.

To attach snowplow to vehicle mount, proceed as follows:

1. Position the vehicle such that the T-frame lugs and vehicle mount are in vertical alignment.
2. Hook the chain into the lift channel slot.
3. Actuate lift cylinder slowly. Blade will remain on the ground, but the T-frame will begin to rise. Continue until the T-frame lug holes align with the holes on the vehicle lift frame.
4. Insert the bolt 5/8" x 3 (26) through the holes to attach the T-frame to the lift frame and secure attachment with 5/8" lock nut (27).
5. With the control switch in the DOWN position, push the lift channel downward as far as possible and adjust the chain so there are two links of slack.



Installation of the shoe bracket on Arctic  
Light Duty Poly Blade 78" and 84"  
2018 & older

## Installation of shoe bracket 53021-M-GA on ARCTIC LD Poly Blade 78" and 84"

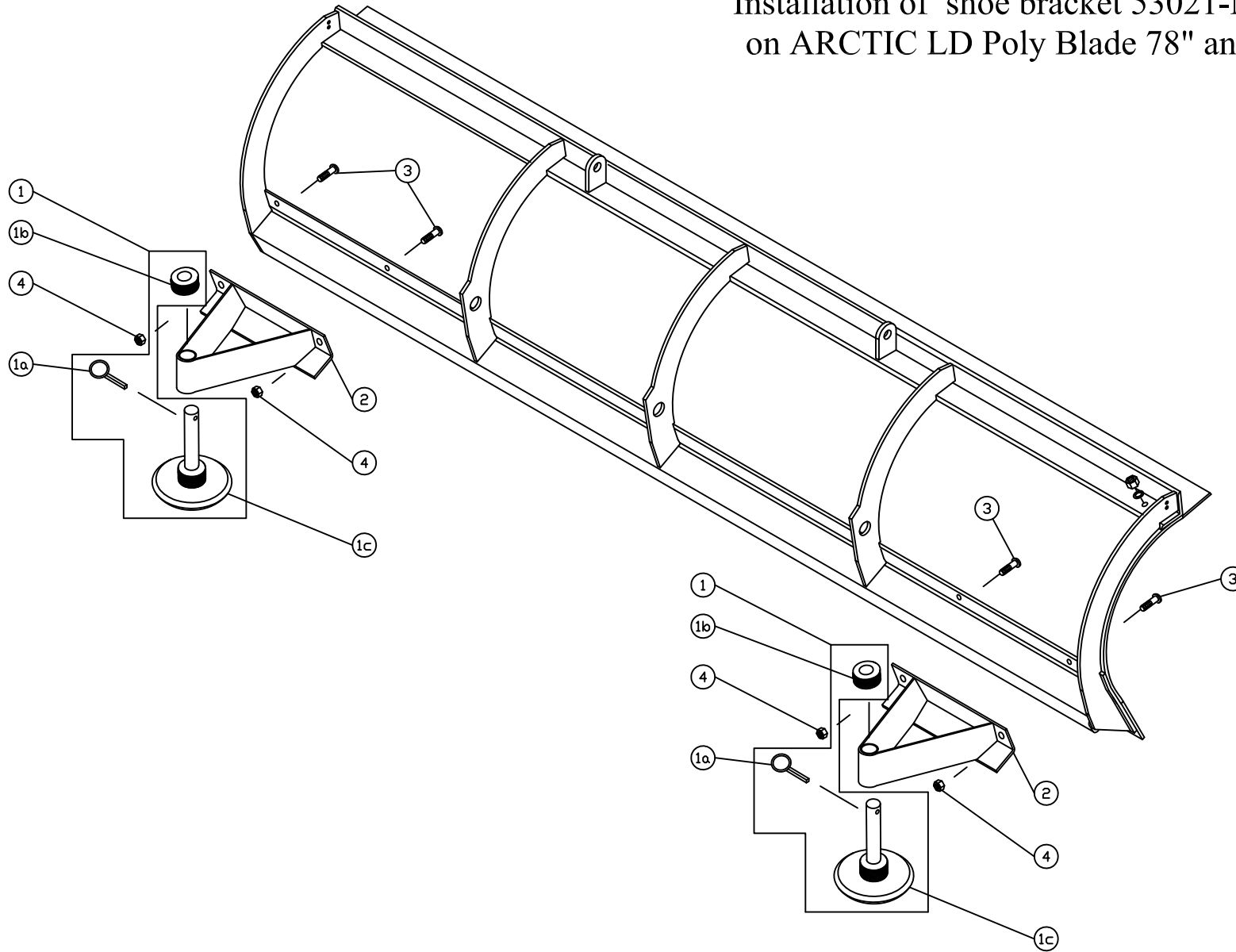

 **Warning**

Do not exceed the gross vehicle weight ratings (GAWR), front gross axle weight rating (FGAWR) or rear gross axle weight rating (RGAWR) specified on the Safety Compliance Certification Label located in the driver's side door opening.

Installation of the shoe bracket 53021-M-GA on ARCTIC LD-P blade Galvanized			
Item	Part Number	Description	Quantity
1	50037-B-GA	Shoe Assembly (includes lynch pin, shoe, washers)	2
1a	50040-A	Lynch Pin	2
1b	55017-N	Shoe Washers	30
1c	50666-B-GA	Shoe Galvanized	2
2	53022-B-GA	Mounting Bracket Galvanized	2
3	HH-00971-135	½" Carriage bolt	4
4	HH-00340-003	½" Hug Nut	4

**Installation instructions**

Caution- Use jack stands to support blade when installing this kit or when adjusting the shoe height to prevent any injury

1. Remove (bottom) 1/4" bolt that holds the poly skin to the blade. Open existing 3/8" hole in the skin and the blade to 17/32" diameter.
2. Install mounting bracket (2) using 1/2" bolt (3) and 1/2" nut (4).
3. Using the second hole in the mounting bracket (2) as guide, drill 17/32" diameter hole in the blade and the skin.
4. Install second 1/2" bolt (3) and 1/2" nut (4).
5. Place a shoe assembly (1) in the mounting bracket, and adjust height of the shoe.

Arctic Equipment Manufacturing Corporation reserves the right under its product improvement policy to change construction or design details and furnish equipment when so altered without reference to illustrations or specifications used.

Installation of the optional spring on Arctic  
Light Duty Poly Blade  
2018 & older

## Installation of optional spring on ARCTIC LD Poly Blade

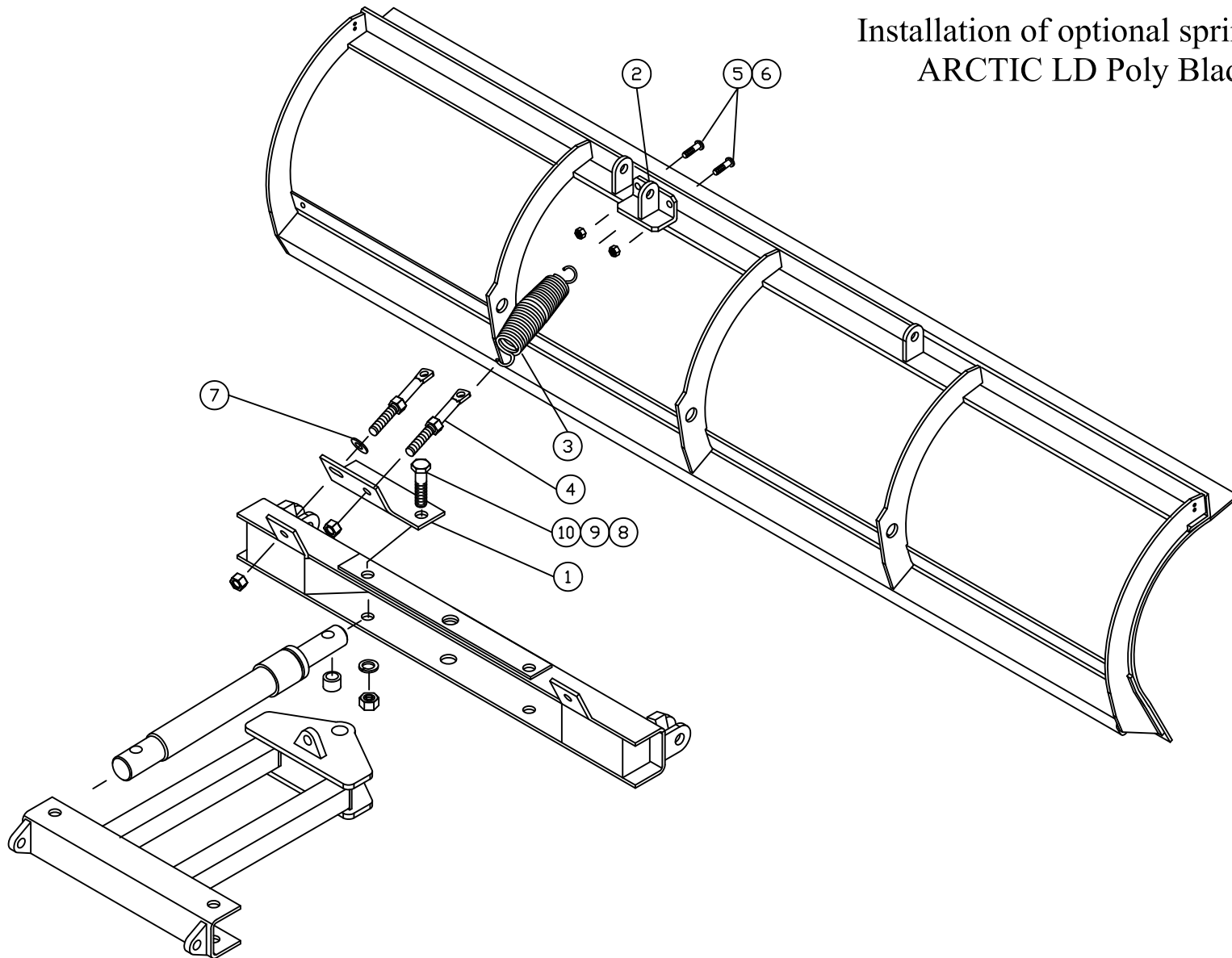

 Warning

Do not exceed the gross vehicle weight ratings (GAWR), front gross axle weight rating (FGAWR) or rear gross axle weight rating (RGAWR) specified on the Safety Compliance Certification Label located in the driver's side door opening.

Optional spring assembly 53035-01-M-GA Assembly Driver Side (shown on the drawing)			
Item	Part Number	Description	Quantity
1	53036-01-A-GA	Bottom Spring Bracket D/S Galvanized	1
2	53037-A-GA	Top Spring Bracket	1
3	52663-N	Spring	1
4	50191-M	Eye Bolt Assembly (eye bolt 5/8" and 2 nuts)	1
5	HH-00971-135	½" Carriage bolt	2
6	HH-00340-003	½" Hug Nut	2
7	HH-00341-008	5/8" Flat washer	1
8	HH-00460-007	3/4" UNF Nut	1
9	HH-00457-008	3/4" Lock washer	1
10	HH-00972-157	3/4" x 5 UNF Hex Head Cap Screw	1

Optional spring assembly 53035-02-M-GA Assembly Curb Side (not shown on the drawing)			
Item	Part Number	Description	Quantity
1	53036-02-A-GA	Bottom Spring Bracket C/S Galvanized	1
2	53037-A-GA	Top Spring Bracket	1
3	52663-N	Spring	1
4	50191-M	Eye Bolt Assembly (eye bolt 5/8" and 2 nuts)	1
5	HH-00971-135	½" Carriage bolt	2
6	HH-00340-003	½" Hug Nut	2
7	HH-00341-008	5/8" Flat washer	1
8	HH-00460-007	3/4" UNF Nut	1
9	HH-00457-008	3/4" Lock washer	1
10	HH-00972-157	3/4" x 5 UNF Hex Head Cap Screw	1

### Installation instructions

1. Install the bottom spring bracket (1) on the quadrant using 3/4" bolt (10), 3/4" lock washer (9) and 3/4" nut (8) that holds the cylinder in place and existing eye bolt (a 5/8" flat washer (7) needs to be installed under the 5/8" nut - see drawing).
2. Place the top spring bracket (2) on the top angle of the blade (the lug on the top spring bracket should be in same line as hole in bottom mounting bracket). Using holes in the top mounting bracket as a guide drill two 17/32" holes. Install two 1/2" carriage bolts (5) and hug nuts (6).
3. Install an eye bolt (4) and a spring (3). Apply tension on the spring (3) until you see that coils have started to separate.

Arctic Equipment Manufacturing Corporation reserves the right under its product improvement policy to change construction or design details and furnish equipment when so altered without reference to illustrations or specifications used.